

# OWNERS and SERVICE MANUAL for



**MODEL 345**

This binder contains the complete owners and technical manuals for the Memorymoog. As updates and improvements are made in the instrument, they will be described in the Addenda section in the back of the manual.

# MEMORYMOOG OWNERS MANUAL

## CONTENTS

INTRODUCTION .....	1
SECTION I	
Setting Up .....	2
Calling Up Programs .....	3
Editing A Sound .....	3
Calling Up and Stepping Through Program Sequences .....	4
SECTION II	
Keyboard/Performance Controls .....	5
Left-Hand Controllers .....	7
System Controller .....	7
Footpedals .....	10
LFO Modulation .....	10
Oscillators .....	12
Mixer .....	13
Voltage Controlled Filter .....	13
Voltage Controlled Amplifier .....	14
Contour Controls .....	14
Outputs .....	15
The Back Panel .....	15
Hi-Level Audio Output .....	15
Footpedal In .....	15
External Synthesizer Out .....	16
Footswitch In .....	16
Cassette Interface .....	16
Power On/Off .....	16
Powercord .....	16
SECTION III	
The System Controller .....	17
Calling Up Programs .....	17
Recording Programs .....	18
Program Sequences .....	20
Loading Your Own Program Sequence .....	20
The Cassette Interface .....	22
Interfacing the Memorymoog to a Monophonic Synth .....	22
The Keyboard .....	23
Changing the Number of Voices the Keyboard Controls in Mono Mode .....	25
Single/Multiple Trigger .....	25
The Hold Function .....	26
The Arpeggiator .....	26
The Oscillators .....	27
Waveshape .....	27
Sync 2 to 1 .....	28

## CONTENTS (Continued)

Frequency Controls .....	29
Osc 3 as a Low-Frequency Oscillator .....	30
The Noise Source .....	30
The Mixer .....	30
The Voltage-Controlled Filter .....	31
Emphasis .....	31
KB Track .....	32
Contour Amount .....	33
The Contour Generators .....	33
Contour Mode Controls .....	35
Unconditional Contours .....	36
Keyboard Follow .....	37
Outputs .....	38
Modulation .....	39
LFO Modulation .....	39
Voice Modulation .....	43
The Programmable Footpedals .....	48
MEMORYMOOG SOUND CHARTS .....	49

# INTRODUCTION

The Memorymoog is a voice-assignment polyphonic synthesizer with the ability to store up to 100 patches in computer memory. It has six independent voices, each containing three voltage-controlled oscillators, a voltage-controlled 24dB/octave lowpass filter, two ADSR contour generators, and extensive modulation facilities. This means that there are 18 oscillators, six filters, and 12 contour generators in the unit. However, there is a single set of controls for those components, meaning that their sound is programmed homophonically - each program governs each voice identically.

At the heart of the Memorymoog is the System Controller which gives you command over the instrument's microprocessor. With the System Controller you can change programs, store patches, change keyboard modes, use the cassette interface, alter arpeggiation mode, and set up program sequences. Learning to use the System Controller is the key to learning how to use the Memorymoog.

This manual is designed in sections, starting with a quick setup guide for those of you who are in a hurry to quit reading and start playing. It tells you some dos and don'ts about setting up and explains what you'll need to know about the System Controller in order to get at the programs. Section II is a reference guide designed to help answer any questions regarding specific features on the Memorymoog. Section III is a step-by-step explanation of each set of controls for those of you who aren't all that familiar with synthesis. It's designed to help clarify things that may seem vague in Section II. The final section of the manual deals with service information and contains schematics and maintenance details. A sound chart section is included that contains diagrams of all the factory programs. Some blank panel diagrams are also provided for you to copy down your own patches.

# SECTION I

## SETTING UP

If you haven't bought a flight case for your Memorymoog, save the carton it came in in case you have to arrange long distance transportation.

After unpacking your instrument, hook it up to a wall socket by first inserting the detachable three-pronged cord into the back of the Memorymoog and then into the power outlet. Be sure that the outlet is putting out the right amount of voltage.

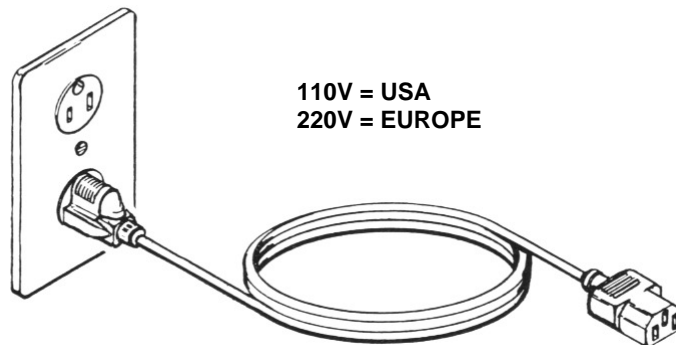

If you want to operate your Memorymoog on a voltage that differs from what's coming out of the wall socket, i.e. 220 instead of 110 or 110 instead of 220, an authorized Moog service center can set up your instrument to operate at the proper voltage.

Next hook any footpedals or switches you desire to use up to their respective inputs. Then connect the audio output of the Memorymoog to an amplification system using either an XLR cable or a 1/4" phone jack. A high quality amp is desirable due to the wide frequency range of the Memorymoog. Also, note that different amps will make the programs sound different.



Turn the output volume of both the Memorymoog and the amp down to zero. Turn the Memorymoog on and then turn the amp on. Bring the volume of the amp up to where you're used to setting it. While holding down a note, bring the MASTER VOLUME control (at the upper right corner) up until it's at a comfortable level.

After you've turned the instrument on, let it warm up for about 10 minutes to allow the oscillators to stabilize. Then hit the AUTO TUNE control in the upper left-hand corner. This will tune the Memorymoog's 18 oscillators. Notice that the SYSTEM CONTROLLER's Alphanumeric Display reads "6 TUNED" after the tuning cycle is complete, indicating that all six voices have been tuned. If a number less than six appears in the screen, it means that the system was unable to tune one or more of the oscillators for some reason. Try hitting the AUTO TUNE switch again if this occurs. If they still fail to tune, they can be manually disabled. Refer to the Service Section of the manual for details.

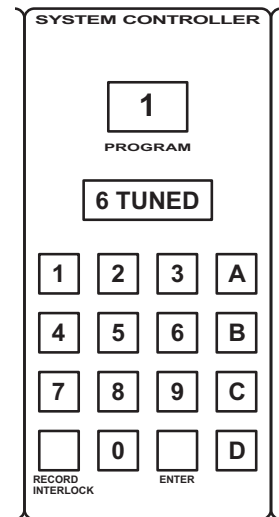

### CALLING UP PROGRAMS

When you first turn the Memorymoog on, program Number 1 will appear in the PROGRAM DISPLAY window of the SYSTEM CONTROLLER. To change program numbers, hit any number from 0 to 99 followed by hitting the ENTER button on the Numeric Keyboard of the SYSTEM CONTROLLER.

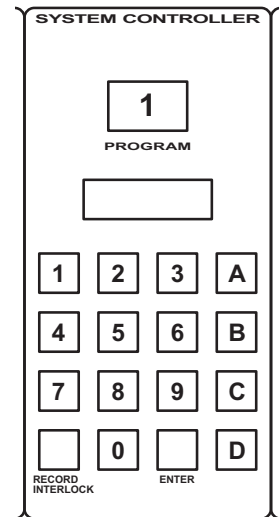

EDIT }  
030 052 }

### EDITING A SOUND

Changing or editing programs is very simple. If you want to alter some aspect of any of the sounds supplied by the factory, all you have to do is hit any of the switches (except those in the SYSTEM CONTROLLER) or hit any of the rotary controls (pots). You'll notice that when you hit a switch the Alphanumeric Display will read "EDIT," and when you turn a pot, six numbers appear in the display screen.

The group of three numbers on the left indicates the value of the pot as it is in the program memory, and the group of three numbers on the right indicates the current value of the pot.

Hitting the ENTER button will immediately restore the program values.

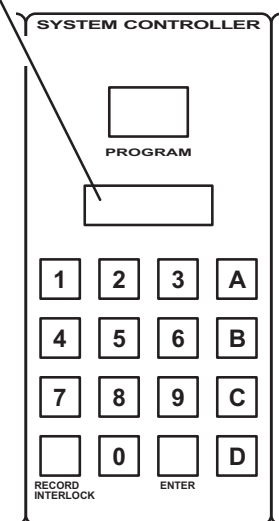

## CALLING UP AND STEPPING THROUGH PROGRAM SEQUENCES

To get into the PROGRAM SEQUENCE MODE hit PREFIX letter D, followed by any number from 0 to 9, followed by ENTER. This gets you to one of the 10 PROGRAM SEQUENCES. What will appear in the Alphanumeric Display looks like this:

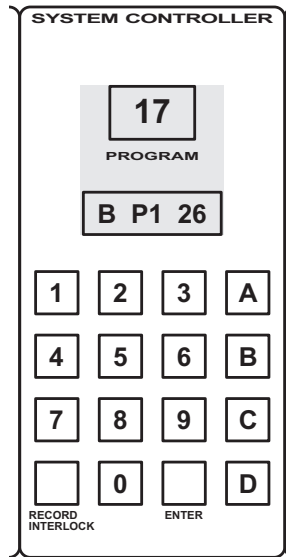

The number in the PROGRAM DISPLAY is the first program of the PROGRAM SEQUENCE. The B at the left of the screen indicates the beginning of the SEQUENCE. As you step through the SEQUENCE, the number that appears in this spot indicates the previous program number. The center of the display shows the PROGRAM SEQUENCE number, and the number to the right of the screen is the program number next in line in the SEQUENCE.

To step through the PROGRAM SEQUENCE, use the A PREFIX switch to go forward and the B PREFIX switch to go backward. You can also use PROGRAM ADVANCE and PROGRAM BACKSTEP footswitches for these functions. (Note that the footswitches aren't supplied with the instrument.)

Experimenting with the programs, editing them, and stepping through the PROGRAM SEQUENCES should keep you busy for at least a few minutes. It should also start generating questions about other features on the instrument. Section II of the manual provides brief descriptions of all the various functions of the Memorymoog, while Section III offers step-by-step explanations. From this point, refer to those sections as the need arises.

## SECTION II

This section of the Memorymoog manual is designed to answer questions about the function of each control on the front and back panels of the instrument. It's a quick reference guide; more detailed explanations will be found in the next portion of the manual.

### 1.0 KEYBOARD/PERFORMANCE CONTROLS.

#### 1.1 AUTO TUNE.

Touching this switch causes the computer in the unit to tune the 18 oscillators. Tuning takes about 8 seconds. The instrument will be "dead" for that period of time. The SYSTEM CONTROLLER's (3.0) Alphanumeric Display will show "TUNING" when the switch is initially depressed, and it will show how many voices have been tuned at the end of the tuning cycle.

#### 1.2 TUNE.

Lets you fine tune the instrument over a range of  $\pm 3$  semitones. This is a non-programmable control and will affect all voices identically.

#### 1.3 MONO.

This switch puts the instrument into the monophonic mode - it will play only one key at a time. The number of voice cards you control is variable from I up to 6, giving you control over from 1 to 18 oscillators. This is programmed by the SYSTEM CONTROLLER (3.0) and the MIXER section (7.0).

#### 1.4 MULTIPLE TRIGGER.

When on, the keyboard triggers all contours when any new keys are depressed. When off, new notes trigger only the assigned voice.

#### 1.5 KB OUT.

KEYBOARD OUT controls the trigger and voltage outputs from the EXTERNAL SYNTHESIZER OUTPUT section (14.0). It's used when controlling an external synthesizer. When on, the Memorymoog will control the external synthesizer.

#### 1.6 GLIDE AMOUNT AND GLIDE ON/OFF.

The glide is both monophonic and polyphonic. When the instrument is in mono mode, a master glide circuit takes over for the 6 separate glide circuits that work when it's in polyphonic mode, and allows the instrument to glide in unison. Glide is linear. Maximum glide time between the outer notes of the keyboard is about 10 seconds.

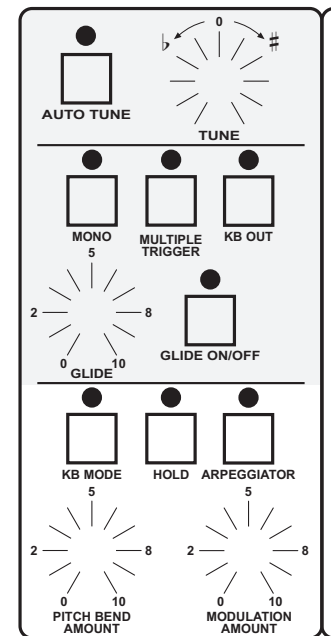

### 1.7 KB MODE.

KEYBOARD MODE affects the priority of the keyboard when it's in both mono and polyphonic modes. In mono mode, the SYSTEM CONTROLLER (3.0) Alphanumeric Display shows either "MONO 1, 2 or 3," depending on the mono mode programmed. Mono 1 is last-note priority, Mono 2 is low-note priority, and Mono 3 is high-note priority. In polyphonic mode, the Alphanumeric Display will show either "POLY 1" (cyclic), "2" (cyclic with memory), "3" (reset to voice A), or "4" (reset to voice A with memory). Voltages routed to an external synth via the EXTERNAL SYNTHESIZER OUTPUT (14.0) are affected by this control.

### 1.8 HOLD.

Lets you build up chords and transpose them in parallel motion from the keyboard. Holding a chord and then pressing the HOLD button will memorize the chord. Holding down the HOLD button and then pressing notes on the keyboard will let you build widely spaced chords. Releasing the HOLD button memorizes the chord. The chord can then be transposed from the last note you played on the keyboard.

### 1.9 ARPEGGIATOR.

Continuously triggers note played on the keyboard. Rate is set by the LFO (5.0) speed. The Clock can be overridden by an external trigger source at the CLOCK IN (15.5) on the back panel. The internal clock is reset by the keyboard so you can always play in time. The Arpeggiator operates in six different modes:

- 1) Plays back notes from bottom to top, unlatched (notes stop when you lift off the keyboard).
- 2) Plays back notes from top to bottom, unlatched.
- 3) Plays back notes from top to bottom, and then from bottom to top, unlatched.
- 4) Plays back notes from bottom to top (latched). The notes will continue if you lift your hands off the keyboard.
- 5) Plays back notes from top to bottom, latched.
- 6) Plays back notes from top to bottom, and then from bottom to top, latched.

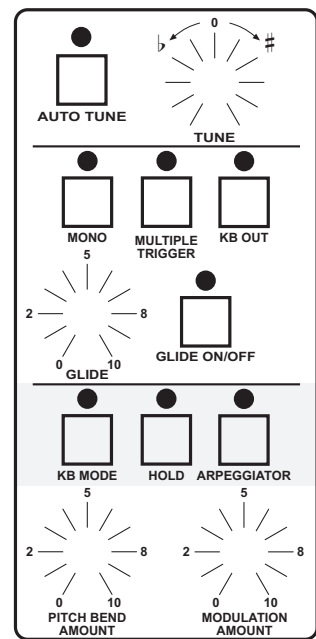

### 1.10 PITCH BEND AMOUNT.

Lets you vary the maximum range of the PITCH BENDING WHEEL (2.2) up to  $\pm 1$  octave. Note that this control is programmable.

### 1.11 MODULATION AMOUNT.

Sets a programmable initial modulation amount. The MODULATION WHEEL (2.3) adds to the amount set by this control.

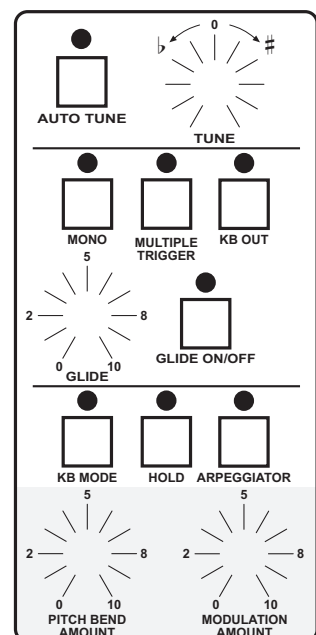

## 2.0 LEFT-HAND CONTROLLERS.

### 2.1 OCTAVE SWITCHES.

These are not programmable. They raise or lower the pitch of all oscillators by one octave.

### 2.2 PITCH WHEEL.

Lets you bend the pitch of what's played on the keyboard by an amount determined by the PITCH BEND AMOUNT control (1.11).

### 2.3 MODULATION WHEEL.

For injecting modulation from the LFO (5.0). Adds to the initial amount of modulation programmed by the MODULATION AMOUNT control (1.12).

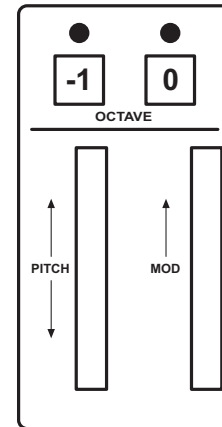

## 3.0 SYSTEM CONTROLLER.

### 3.1 PROGRAM DISPLAY.

The large numeric LED (Light Emitting Diode) display shows which program number has been called up. Program numbers range from 0 to 99.

### 3.2 ALPHANUMERIC DISPLAY.

Through this display, the Memorymoog's computer conveys various sorts of information about what is going on in the instrument. When the AUTO TUNE cycle is complete, it will display how many voice cards have been tuned up by showing "1, 2, 3, 4, 5 or 6 TUNED." Note that any number less than 6 indicates that the computer couldn't tune one of the voice cards for some reason.

If you change any part of the current program in the display by activating a control pot or switch, it will read "EDIT." If you've changed a rotary pot's position, the left side of the display will show the value of that pot as it is in memory, while the right side displays the current value. With this readout, you can match old programs or return a pot to its original value.

Keyboard mode is indicated on the Alphanumeric Display when you hit the KB MODE switch (1.7). When the RECORD INTERLOCK button (3.4) is hit, the display will read "LOCK." When a program has been recorded into memory the display will read "RECORDED."

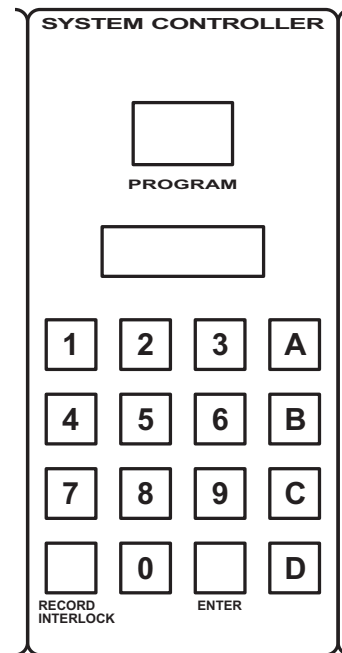

### 3.3 NUMERIC KEYBOARD.

This calculator-type keyboard is used for calling up programs and other control functions. You do this by hitting one or two numbers (from 0 to 99) and then pressing the ENTER button.

### 3.4 RECORD INTERLOCK.

This switch is used to temporarily lock the front panel settings in memory. By hitting LOCK, the Alphanumeric Display (3.2) will read "LOCK," indicating that the current panel settings are temporarily locked, and turning pots or hitting switches will have no effect. This allows you to call up another patch from memory (by hitting a number and pressing ENTER) without losing the locked patch. Hitting the LOCK switch after you've called up another patch will bring up the locked patch. This is useful for checking edited patches against the original version.

### 3.5 STORING A PATCH IN MEMORY.

This is done by holding the LOCK button (3.4) down and hitting the ENTER button (see 3.3). This loads whatever is currently shown on the front panel into the memory position called up in the Program Display (3.1). Note that recording a patch is impossible if the Memorymoog is "write disabled," meaning that a protect function against storing unwanted information in memory is on. To turn the protect function off and on, you must know the four-digit security code (see Section III). Attempting to store a patch in memory when the disable feature is on will cause the Alphanumeric Display (3.2) to read "DISABLED." When a patch has been successfully written into a memory position the Alphanumeric Display will read "RECORDED."

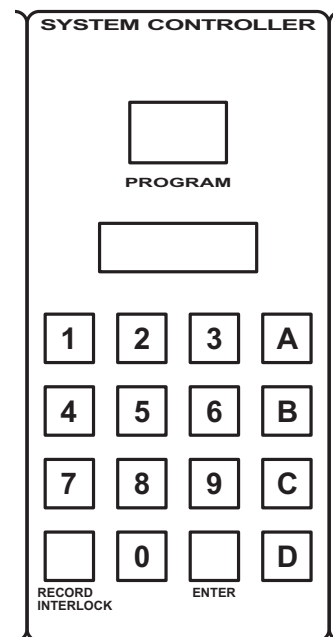

### 3.6 PREFIX BUTTONS.

**PREFIX A** advances programs stored in the PROGRAM SEQUENCE MODE (see below). Also advances program number by one in normal operating mode.

**PREFIX B** steps in reverse through the programs in the PROGRAM SEQUENCE MODE (see below). Backsteps program number by one in normal operating mode.

**PREFIX C1** (hit C, hit 1, hit ENTER) saves programs onto cassette tape (for more information on this procedure see the next section of the manual).

**PREFIX C2** (hit C, hit 2, hit ENTER) loads programs from cassette tape into the Memorymoog's memory.

**PREFIX C3** (hit C, hit 3, hit ENTER) verifies correct loading of programs when putting programs from the Memorymoog onto cassette tape.

**PREFIX C4** is used for defeating voices that aren't tuning up for whatever reason. See text in next section of the manual for details.

**PREFIX C5** tunes all oscillators to unison, regardless of front panel settings.

**PREFIXES C6** and **C7** are electronic tuning aids for service technicians.

**PREFIX C8** displays current memory status, **ENABLED** or **DISABLED** in the Alphanumeric Display (3.2). The unit powers up with the memory disabled so that you can't accidentally record a patch and you can't use the cassette interface functions of PREFIXES C1, 2, and 3. To enable the memory store function, hit C8 followed by the four-digit security code (see Section III). Hitting the letter C after entering C8 tells the instrument that you want to change the security code. Do this by entering the old four-digit code (the code of instruments fresh from the factory is 0000); the display will read "NEW CODE" or "BAD CODE" depending on if you have it right or not. If the old code is correct, you may then enter any new four-digit code.

**PREFIX C9** makes the front panel live. The Alphanumeric Display (3.2) will read "LIVE PNL" when you hit C, hit 9, hit ENTER. In this state, the front panel controls override the memory settings.

**PREFIX C0** flashes all the LEDs. This is another service function to check if all the LEDs work. Hitting any switch turns the function off.

**PREFIXES D0** to **D9** call up PROGRAM SEQUENCES. These are chains of up to 20 programs, each arranged in some predetermined order. To call one up hit D, hit a number from 0 to 9, and hit ENTER. To load a PROGRAM SEQUENCE, hit D, hit D again, hit a number from 0 to 9 and hit ENTER to get into PROGRAM SEQUENCE LOADING MODE. Then to enter programs, hit the program number, hit ENTER, hit A (ADVANCE switch) or B (BACKSTEP switch). Repeat until you've loaded all the programs you require. The loading mode will stop after 10 programs are loaded. You can also use the ADVANCE and BACKSTEP footswitches (15.3 and 15.4) to step forward and backward in the PROGRAM SEQUENCE.

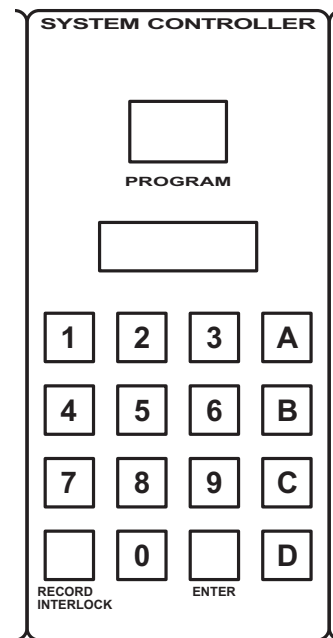

## 4.0 FOOTPEDALS.

### 4.1 AMOUNT 1, PITCH, VOLUME, FILTER.

The AMOUNT knob controls the overall range of footpedal number 1 which can be routed to control the pitch of all the oscillators, the volume, and the filter's cutoff frequency. Functions are programmable.

### 4.2 AMOUNT 2, MOD AMT, OSC 2.

Determines the range of a second voltage pedal which can be routed to control the amount of modulation and/or the frequency of the second oscillator.

**NOTE:** Footpedals are not supplied with the instrument. The inputs on the back panel (13.0) will use any voltage input that ranges from 0 to 5 volts. If you plug in just one pedal, the input will cross-couple so that one footpedal will control whatever is called up on either PEDAL 1 or PEDAL 2's programs.

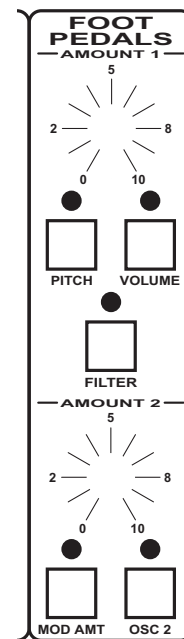

## 5.0 LFO MODULATION.

The amount of modulation is controlled by the MODULATION AMOUNT knob (1.12) and the MODULATION WHEEL (2.3).

### 5.1 RATE (HZ).

Controls the LFO frequency. Variable from .1 Hz to 100Hz.

### 5.2 WAVESHAPES SELECTION.

Five switches to the right of the RATE (5.1) knob for selecting triangle, positive-going saw-tooth, negative-going sawtooth, square, or sample-and-hold waveshapes for the low frequency oscillator. Selecting one waveshape excludes the others; waveshapes can't be intermixed.

### 5.3 DESTINATION SWITCHES.

The output of the LFO can be routed to seven places. It can be used to modulate the frequencies of oscillator 1 (OSC 1), oscillator 2 (OSC 2), oscillator 3 (OSC 3), the pulse width of oscillator 1 (PW 1), the pulse width of oscillator 2 (PW 2), the pulse width of oscillator 3 (PW 3), and/or the filter's cutoff frequency.

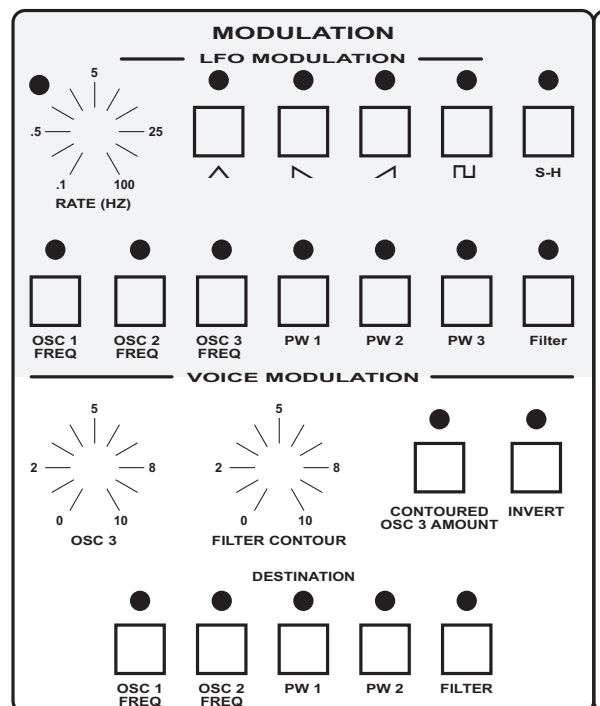

### 5.4 VOICE MODULATION.

The source of this modulation is selectable from either the filter's contour generator or the third oscillator. These affect each voice independently. Voice Modulation is independent of the LFO Modulation (5.0).

### 5.5 OSC 3.

Controls the amount of modulation from oscillator 3.

### 5.6 FILTER CONTOUR.

Controls the amount of modulation from the filter's contour generator.

### 5.7 CONTOURED OSC 3 AMOUNT.

When switched on allows the filter's contour generator to shape the amount of modulation coming from oscillator three. This is useful for creating modulation effects that vary with time.

### 5.8 INVERT.

Inverts the filter contour as it's applied to the CONTOURED OSC 3 AMOUNT (5.7) and inverts the output of OSC 3 (6.0).

### 5.9 DESTINATION SWITCHES.

Voice Modulation can be routed to five places using this set of switches: the frequency of oscillator 1 (OSC 1 FREQ), the frequency of oscillator 2 (OSC 2 FREQ), the pulse width of oscillator 1 (PW 1), the pulse width of oscillator 2 (PW 2), and/or the filter's cutoff frequency (FILTER).

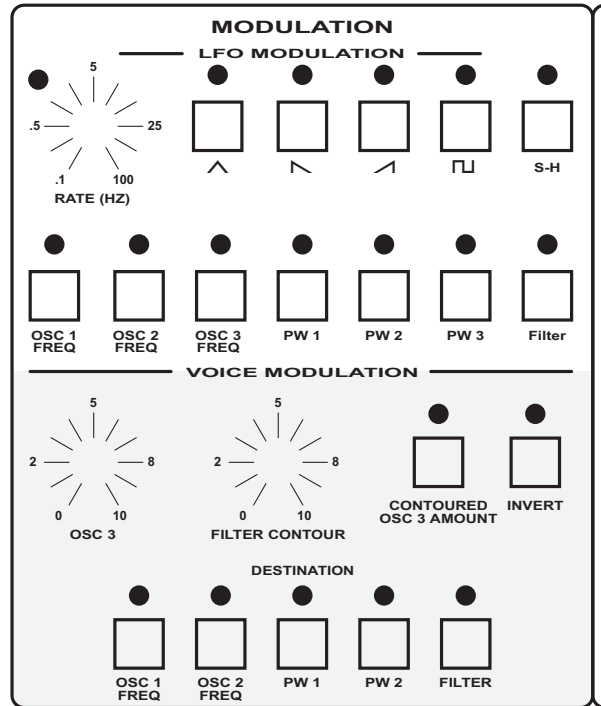

## 6.0 OSCILLATORS.

### 6.1 OCTAVE (oscillators 1, 2, 3).

16', 8', 4', and 2' octave settings for each oscillator are available via these switches. Note that the octave switches in the LEFT-HAND CONTROLLER section (2.0) will raise or lower the pitch of the oscillators one octave.

### 6.2 SYNC 2 TO 1 (oscillator 1 only).

Locks the fundamental frequency of oscillator 2 to that of oscillator 1. It is hard sync.

### 6.3 PULSE WIDTH (oscillators 1, 2, 3).

Varies the width of the rectangular wave-shape from 0 to 100%. At the outer extremes of this range the pulse width will be so narrow that you won't hear any signal.

### 6.4 WAVESHAPES (oscillators 1, 2, 3).

These three switches let you call up pulse, sawtooth, and/or triangle waveshapes. Waveshapes can be combined.

### 6.5 FREQUENCY (oscillator 2).

A dual concentric pot which lets you tune the second oscillator  $\pm$  a minor sixth. The outer ring is for coarse control and the inner ring is for making finer adjustments.

### 6.6 FREQUENCY (oscillator 3).

Tunes the third oscillator  $\pm$  a minor sixth. However, when the KEYBOARD CONTROL switch (6.8) is off or the LOW switch (6.7) is on, the range of this knob is increased to  $2 \frac{1}{2}$  octaves.

### 6.7 LOW (oscillator 3 only).

Drops the frequency of oscillator 3 by approximately 5 octaves, converting it to a low frequency oscillator. With this switch on, the range of the FREQUENCY control (6.6) is increased to  $2 \frac{1}{2}$  octaves.

### 6.8 KEYBOARD CONTROL (osc 3 only).

For turning on and off the keyboard control voltage routed to oscillator 3. With the keyboard control voltage off, the range of the FREQUENCY control (6.6) is increased to  $2 \frac{1}{2}$  octaves.

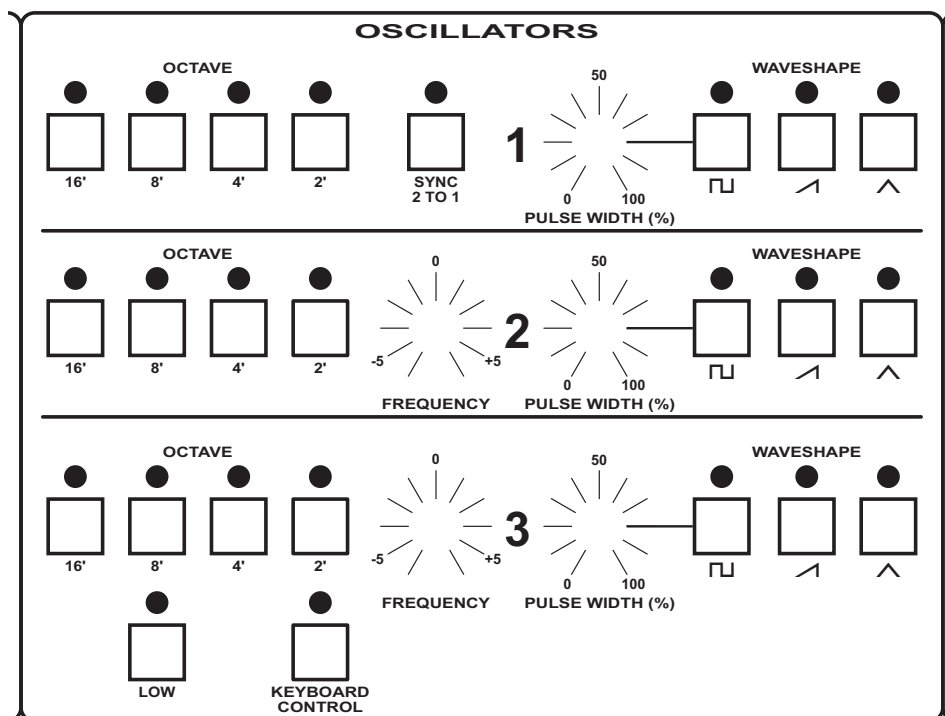

### 7.0 MIXER.

Four level controls for adjusting the relative volumes of the three oscillators and a pink noise source as they feed into the filter. Note that beyond a setting of 4 or 5, these controls cause the signals to clip (distort). This gives a little more punch to a sound where desired. It also turns the triangle waves into sine waves. At a setting of 10 you will hear some intermodulation distortion.

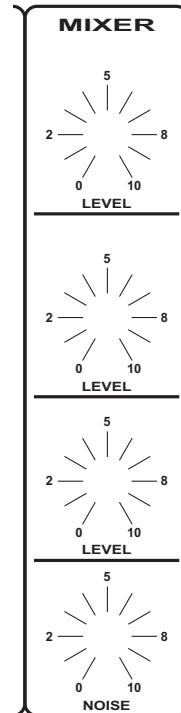

### 8.0 VOLTAGE CONTROLLED FILTER.

The Voltage Controlled Filter is the patented Moog 24db/octave low-pass filter.

#### 8.1 KB TRACK.

Varies the amount of voltage from the keyboard that controls the filter cutoff frequency. You can select either } of the keyboard voltage, { of the keyboard voltage, all of the keyboard voltage (both switches on), or no keyboard voltage (both switches off).

#### 8.2 CUTOFF.

Controls the cutoff frequency of the filter.

#### 8.3 EMPHASIS.

Controls the degree of filter resonance. Oscillation begins at a little past a setting of 7.

#### 8.4 CONTOUR AMOUNT.

Controls the amount of voltage from the FILTER CONTOUR GENERATOR (8.5) that is applied to the cutoff frequency.

#### 8.5 FILTER CONTOUR GENERATOR.

#### 8.6 ATTACK.

Varies the attack time from 1 millisecond to 10 seconds.

#### 8.7 DECAY.

Variable from 2 milliseconds to 20 seconds.

#### 8.8 SUSTAIN.

Varies the sustain level of the filter contour.

#### 8.9 RELEASE.

Adjustable from 2 milliseconds to 20 seconds. The RELEASE SWITCH (10.4) and/or the RELEASE FOOTSWITCH (15.1) turn the release portion of the contour on and off.

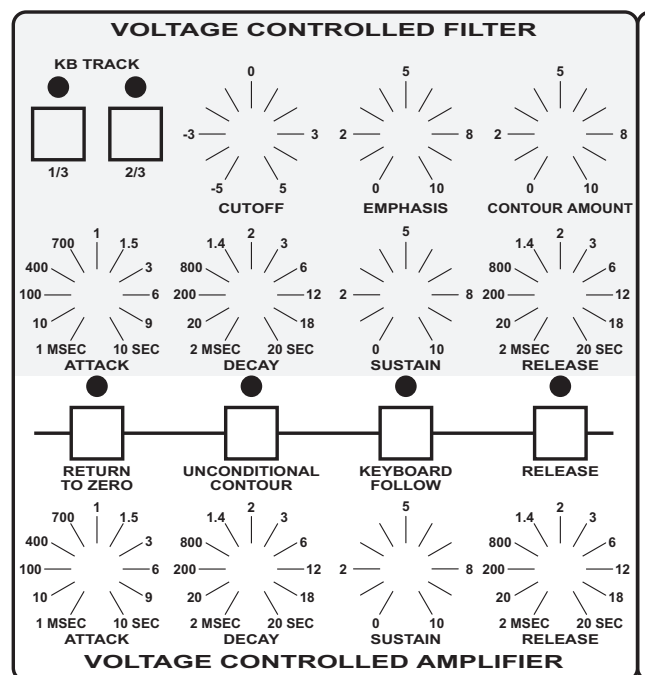

## 9.0 VOLTAGE CONTROLLED AMPLIFIER.

An ADSR contour generator controls the VCA.

### 9.1 ATTACK.

Same as section 8.6.

### 9.2 DECAY.

Same as section 8.7.

### 9.3 SUSTAIN.

Same as section 8.8.

### 9.4 RELEASE.

Same as section 8.9.

## 10.0 CONTOUR CONTROLS.

This set of four switches affects both Contour Generators.

### 10.1 RETURN TO ZERO.

Normally, the Contour Generators, if retriggered during the attack segment, start from the existing voltage level. With this switch on, the attack segment will always reset to zero volts.

### 10.2 UNCONDITIONAL CONTOUR.

With this switch off, the Contour Generators will go into their release states (if the RELEASE SWITCH [10.4] is on or the RELEASE FOOT SWITCH [15.1] is depressed) only when you let up on a key. With the switch on, when you let up on a note, the Contour Generators will go through their entire attack phase and then jump immediately into the release state.

### 10.3 KEYBOARD FOLLOW.

When this switch is on, the voltage from the keyboard varies the attack, decay and release times of the Contour Generators. The lower you play, the longer the times; the higher you play, the shorter the times.

### 10.4 RELEASE.

Turns the release segment of the Contour Generators on and off. This control interacts with the RELEASE FOOTSWITCH (15.1).

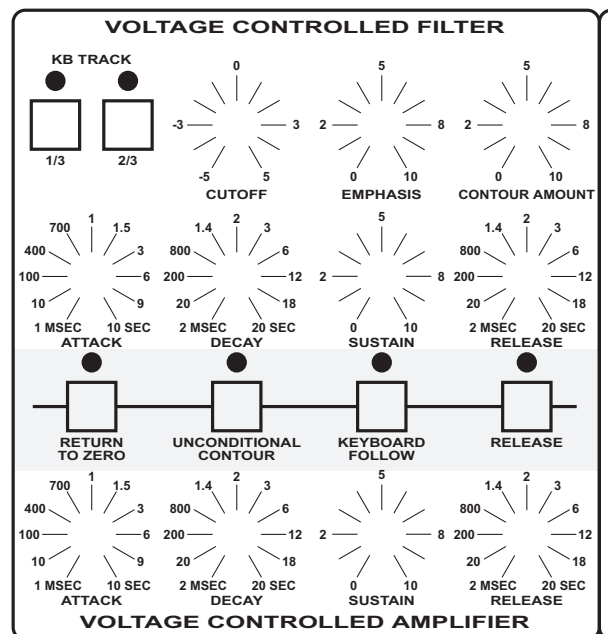
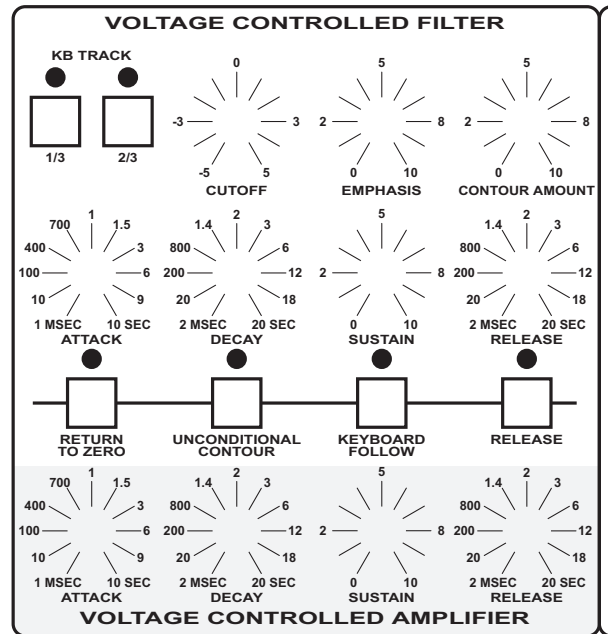

## 11.0 OUTPUTS.

### 11.1 MASTER VOLUME.

A non-programmable volume control.

### 11.2 PROGRAMMABLE VOLUME.

Used for matching volume levels between programs.

### 11.3 HEADPHONE VOLUME.

A non-programmable volume control that's independent of the MASTER VOLUME control (11.1 ). It adjusts the level of the stereo headphone output.

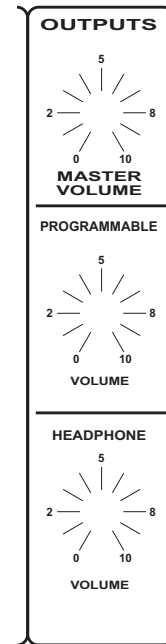

## THE BACK PANEL

### 12.0 HI-LEVEL AUDIO OUTPUT.

#### 12.1 BALANCED.

A transformer-balanced 600 ohm output.

#### 12.2 UNBALANCED.

An unbalanced low-impedance output.

### 13.0 FOOTPEDAL IN.

#### 13.1

Input for a 5-volt voltage pedal controller whose function is programmed on the front panel (see 4.0).

13.2 Input for a 5-volt voltage pedal controller whose function is preprogrammed on the front panel (see 4.0).

Note that inputs 1 and 2 (13.1 and 13.2) are crosscoupled; if you have only one pedal in, that pedal's voltage will be applied to both front panel pedal sections.

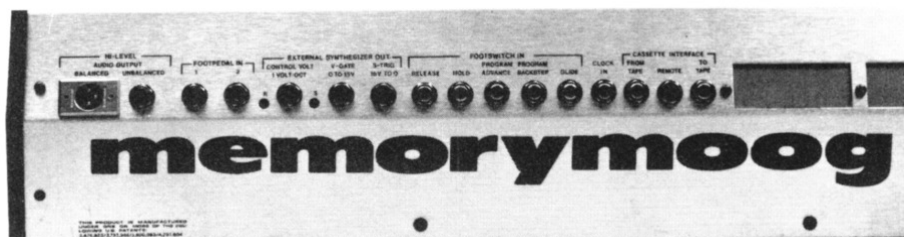

BACK PANEL

## 14.0 EXTERNAL SYNTHESIZER OUT.

### 14.1 CONTROL VOLT 1 VOLT/OCT.

A 1 volt-per-octave ( $\pm 10\%$ ) output for controlling an external synthesizer or synthesizer accessory. Range and scale trimmers for tuning the output to an external synthesizer are accessible through the rear panel.

### 14.2 V-GATE 0 - 15V.

A voltage gate output with a level of from 0 to 15 volts for interfacing with instruments which accept voltage gates.

### 14.3 S-TRIG 15V TO 0.

A switch trigger output with a range of 15 volts to 0 volts. For interfacing to instruments with switch trigger inputs.

## 15.0 FOOTSWITCH IN.

### 15.1 RELEASE.

Accepts a switch input for turning the release portion of the Contour Generators on and off (see 10.4). With the RELEASE switch on the front panel on, depressing the RELEASE FOOTSWITCH will turn the RELEASE switch on the panel off. At that point, the RELEASE FOOTSWITCH will act as a SUSTAIN PEDAL would on a piano: pressed down, the RELEASE function of the CONTOUR GENERATORS (8.5 and 9.0) will be on; let up, the RELEASE function of the CONTOUR GENERATORS will be off.

### 15.2 HOLD.

A switch input for turning the HOLD function (1.8) on and off.

### 15.3 PROGRAM ADVANCE.

A switch input for advancing through the PROGRAM SEQUENCES (3.7).

### 15.4 PROGRAM BACKSTEP.

A switch for stepping through the PROGRAM SEQUENCES (3.7) in reverse order.

### 15.5 GLIDE.

Turns the front panel GLIDE switch on or off.

### 15.6 CLOCK IN.

Replaces the internal clock from the LFO (5.0) with an external clock.

## 16.0 CASSETTE INTERFACE.

Connections are made from the three jacks to a cassette recorder for transfer of memory contents to and from tape.

## 17.0 POWER ON/OFF.

Turns the Memorymoog on and off.

## 18.0 POWERCORD.

A detachable cord is supplied with your instrument. Be careful to grasp it by the plug when taking it out of an electrical outlet.



BACK PANEL

# SECTION III

## THE SYSTEM CONTROLLER

The SYSTEM CONTROLLER is the heart of the Memorymoog. Of all the front panel controls, you'll find yourself using the SYSTEM CONTROLLER most frequently. It is used to store and recall patches, set up keyboard modes, set up arpeggiation modes, control program sequencing, access the cassette interface, and many other present and future functions.

When you first power up the Memorymoog, you'll notice that the number 1 appears in the large LED display labeled PROGRAM. This tells you that program #1 is called up and ready to play. This window, the PROGRAM DISPLAY (3.1), will always show which program is currently called up and ready to play, or which program is about to be entered.

As discussed in the quick setup guide, let your instrument warm up for about 10 minutes, press the AUTO TUNE switch (1.1), and let the instrument tune itself before playing. After the AUTO TUNE routine is complete, program #1 will appear again in the PROGRAM DISPLAY and the appropriate LEDs for program #1 will light up. (Should you need to tune the instrument at any time after it's been warmed up, the computer will always remember the state of the panel controls just prior to the tuning routine and return to it.) The Alphanumeric Display (3.2) will read "6 TUNED" indicating that all six voice cards have been tuned successfully. If any number less than six appears you should hit AUTO TUNE again. If all six voice cards still fail to tune, try turning the instrument off for a moment. Then turn it on again and hit the AUTO TUNE switch. If all this fails, contact an authorized service center or call our factory service center for assistance.

### CALLING UP PROGRAMS

To call up a program, hit any desired number from 0 to 99 on the Numeric Keyboard (3.3) and follow it by pressing the ENTER switch.

**The ENTER switch must be pressed in order for a new program to replace the one that is currently called up. The new number appears on the display immediately, but the new program is not active until the ENTER switch is pressed.**

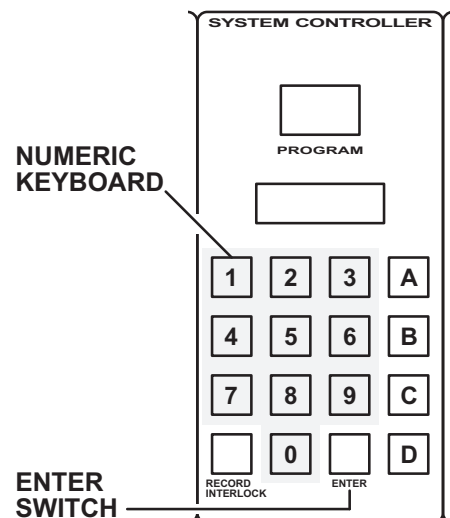
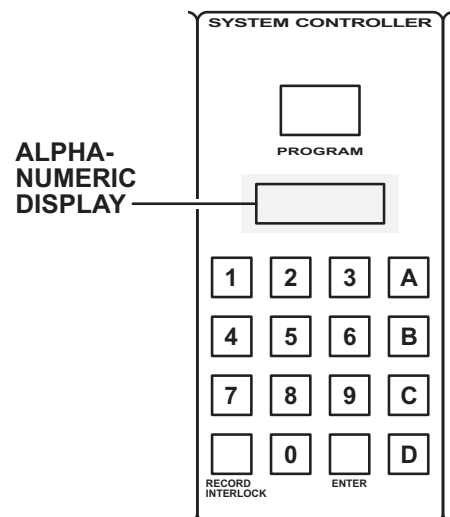
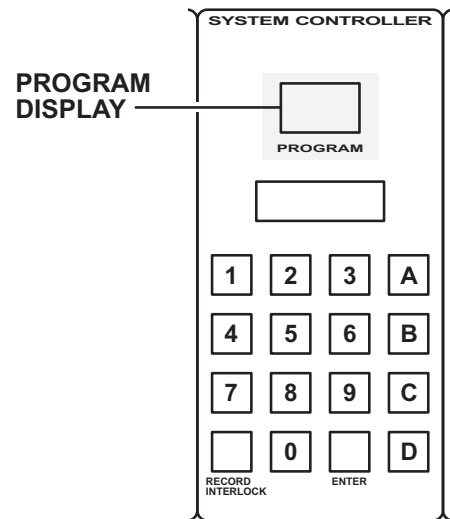

## RECORDING PROGRAMS

In order to record your own patches into the program memory you have to ENABLE the record function. To do this, press PREFIX BUTTON C (3.6), hit 8, and hit ENTER. This will display the status of the instrument. The Alphanumeric Display will read "DISABLED" or "ENABLED." Now you must enter a four-digit security code (when each instrument is shipped, the code is 0000). If you enter the wrong code, the display reads "BAD CODE" and returns to normal operation. If you enter the correct code, the instrument shows the updated status (ENABLED or DISABLED) and returns to normal operation. To change the code, hit C, hit 8, hit ENTER, then hit C again; the instrument assumes you want to change the security code and displays "OLD CODE." You enter the existing code; if the code is incorrect the display reads "BAD CODE," and operation returns to normal. If the code is correct, the display reads "NEW CODE," and you enter any new four-digit code number, followed by ENTER. A convenient code number is the last four digits of your telephone number.

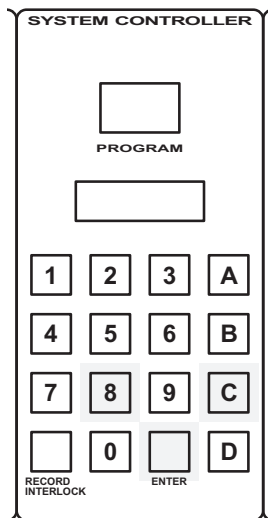

### MEMORY ENABLE/DISABLE PROCEDURE

**PRESS C**  
**PRESS 8**  
**PRESS ENTER = ENABLED OR DISABLED**  
**MEMORY RECORD FUNCTION**

Once you've ENABLED the memory, you're ready to store patches. The memory position you decide on should be one that has a patch you don't want, since once you record another patch over it, it's gone (unless, of course, you've stored it on cassette tape using the procedure explained a little later).

There are two ways of arriving at a patch you like: setting one up from scratch (starting from a "live panel"), or editing (changing) a prerecorded patch. To set up a live panel – one where all the controls are active, overriding the memory values – hit PREFIX C, number 9, and ENTER.

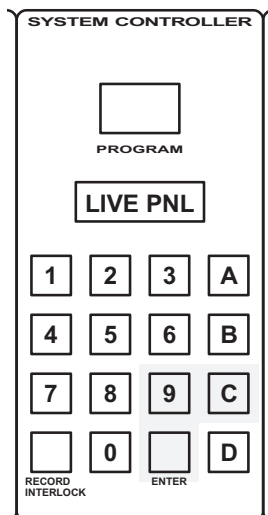

### LIVE FRONT PANEL

**HIT C**  
**HIT 9**  
**HIT ENTER = LIVE PANEL**

To edit or change any preset program, change any of the parameters by moving a pot or pushing a switch. When you hit a switch, you'll notice the Alphanumeric Display will read "EDIT" to tell you you've changed a parameter of the program. If you turn a pot, you'll see six numbers appear in the Alphanumeric Display. The three on the left of the screen tell you what the control's value is in memory, and the three on the right tell you the current value of the control. Note that edit changes aren't permanent changes in the memory. Hitting the ENTER switch at any time while you're editing a sound will immediately restore the patch to its original preprogrammed state. To hear this effect, call up a familiar patch. Make a few edits - changing the CUTOFF of the FILTER, or change the octave settings of the oscillators. Now hit the ENTER switch again. Everything will jump back to the way it was before you edited the sound.

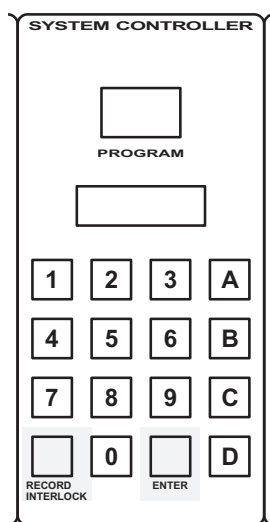

## RECORDING A PATCH

**HIT RECORD INTERLOCK AND HOLD IT  
HIT ENTER = RECORD A PATCH (EITHER  
FROM A "LIVE PANEL" OR  
FROM HAVING EDITED  
A PREPROGRAMMED PATCH)**

Suppose you want to record a new patch. What do you do? There are two ways to go about it:

1) Find the place you want to put it; punch that program number. Hit C, hit 9, hit ENTER to put the panel into a live state. Set up the patch the way you want it, then hit the RECORD INTERLOCK switch. This locks all the front panel controls so that moving them will have no effect at all on the patch as long as the RECORD INTERLOCK switch doesn't get hit again, cancelling the LOCK. Then while holding down the RECORD INTERLOCK switch, press the ENTER button. The Alphanumeric Display will read either "RECORDED" to indicate a successful recording, or "DISABLED" to indicate that the record function of the memory is off and must be turned on to record a patch in memory.

2) The other method of recording a patch involves recording edited versions of programs using the RECORD INTERLOCK switch to freeze them in temporary memory, so they can be moved to other locations or checked against the original patch. Edit a patch, hit the RECORD INTERLOCK switch to put the edited patch in temporary memory and freeze the front panel controls. Now if you hit the ENTER switch (*don't hold the RECORD INTERLOCK button down!*) you'll reinstate the original preset program. Hitting the RECORD INTERLOCK switch will bring back the edited version of the patch. This lets you do A/B comparisons between patches.

Note that you aren't limited to A/B comparisons between the edited patch and its original form. All you have to do is hit the RECORD INTERLOCK switch, putting the edited or live panel patch into temporary memory, and call up the program you want to check it against (hit a number followed by ENTER). To get the LOCKED setting back, hit the RECORD INTERLOCK switch again. If you decide you want to record the LOCKED setting into a memory position, hold the RECORD INTERLOCK switch down and hit the ENTER button. Be sure the PROGRAM DISPLAY is showing the desired program number; otherwise you'll erase a patch you may have wanted to save.

## PROGRAM SEQUENCES

The D PREFIX switch is used to call up and record PROGRAM SEQUENCES. There are 10 PROGRAM SEQUENCES in the Memorymoog. These are chains of up to 20 programs which the user determines.

To call up a PROGRAM SEQUENCE hit D, the PROGRAM SEQUENCE number (any number from 0 to 9), and hit ENTER. What you will see in the PROGRAM DISPLAY is the first program in the PROGRAM SEQUENCE. The Alphanumeric Display will look like this:

### PROGRAM SEQUENCE DISPLAY

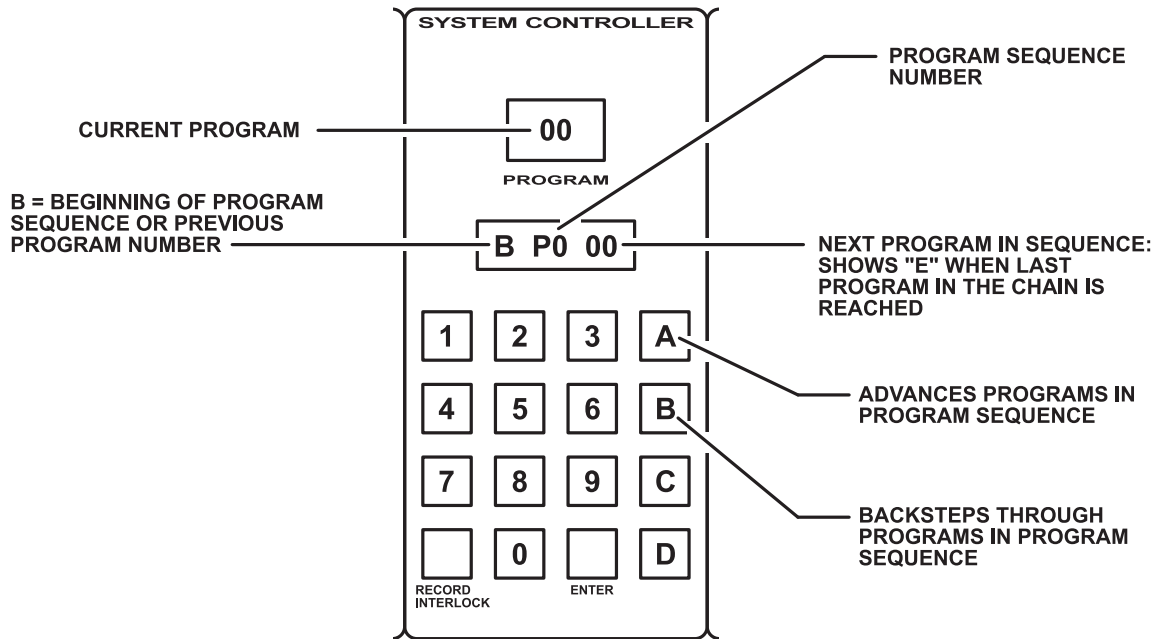

There are two possible methods for stepping forward or backward through the programs in a PROGRAM SEQUENCE. You can use the A and B PREFIX switches on the Numeric Keyboard (see diagram above) or you can use ADVANCE and BACKSTEP footswitches (not supplied with the instrument, but available as Moog accessory number 1122).

The A PREFIX switch advances (steps forward into) the PROGRAM SEQUENCE, while the B PREFIX switch backsteps through the PROGRAM SEQUENCE.

## LOADING YOUR OWN PROGRAM SEQUENCE

This process is fairly simple, but may require some practice until you get the hang of it. The procedure is as follows:

**Hit D** to get yourself into the PROGRAM SEQUENCE MODE. Then **hit D again**, putting you into LOAD MODE (an L will appear in the Alphanumeric Display). **Hit a number from 0 to 9** for the number of the PROGRAM SEQUENCE you wish to load, and then **hit ENTER**.

To load in the first program in the PROGRAM SEQUENCE, hit the number of the program, hit ENTER, and hit A. This will load the first program into the PROGRAM SEQUENCE. Repeat until you've either filled up the PROGRAM SEQUENCE (20 programs maximum for each SEQUENCE), or until you've got all the programs you desire to the maximum number of 20. (Putting less than 20 programs in a chain is possible.)

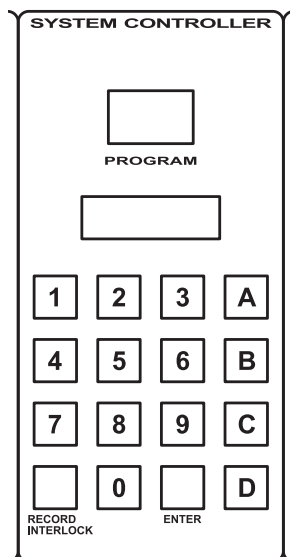

HIT D  
HIT D  
HIT A NUMBER FROM 0 TO 9  
HIT ENTER = LOADING MODE

HIT #  
HIT ENTER  
HIT A  
HIT ENTER = LOAD A PROGRAM FORWARD INTO PROGRAM SEQUENCE

HIT #  
HIT ENTER  
HIT B  
HIT ENTER = LOAD A PROGRAM BACKWARD INTO PROGRAM SEQUENCE

Should you decide that you want to replace a program in the SEQUENCE, you can step through the chain to the program you want to replace and repeat the steps above for recording a program into the SEQUENCE. This will update the PROGRAM SEQUENCE.

Using the B PREFIX switch in place of the A PREFIX switch in the above loading procedure will cause the programs to be loaded into the previous position rather than in the position shown,

Here's a hypothetical PROGRAM SEQUENCE and the procedure for loading it for you to practice on:

The SEQUENCE we want runs programs 10, 20, 30, 40, 50, 60, 70. To load it proceed thus:

- 1) Hit D
- 2) Hit D again
- 3) Hit 0 = load PROGRAM SEQUENCE 0.
- 4) Hit 10
- 5) Hit ENTER
- 6) Hit A = load first program into first position of SEQUENCE 0.
- 7) Hit 20
- 8) Hit ENTER
- 9) Hit A = load second program into second position of SEQUENCE 0.

**CONTINUE** until you've loaded all the programs into the SEQUENCE. To stop loading PROGRAM SEQUENCE 0, hit D again. This will get you out of PROGRAM SEQUENCE MODE. Hitting D, 0, ENTER will recall PROGRAM SEQUENCE 0. Step through it to see if it's correct. The SEQUENCE should run 10, 20, 30, 40, 50, 60, 70. If it doesn't, try to correct your mistake. Correcting mistakes is a great way to familiarize yourself with the operation of the PROGRAM SEQUENCE MODE.

Note that if you should need to run more than 20 programs in a PROGRAM SEQUENCE, the PROGRAM SEQUENCE automatically jumps to the next PROGRAM SEQUENCE number when it has reached the end of a SEQUENCE. Step through to the end of PROGRAM SEQUENCE 0 (an E will appear in the right side of the Alphanumeric Display) and keep going. It will run to PROGRAM SEQUENCE 1. If you step through PROGRAM SEQUENCE 0 backwards (using either the B PREFIX switch or the BACKSTEP footswitch) it will jump to PROGRAM SEQUENCE 9.

## THE CASSETTE INTERFACE

This is used to store information from the memory onto cassette tapes, expanding your library of patches beyond the 100 that the Memorymoog will hold. To access the interface, it's necessary to connect the cassette properly.

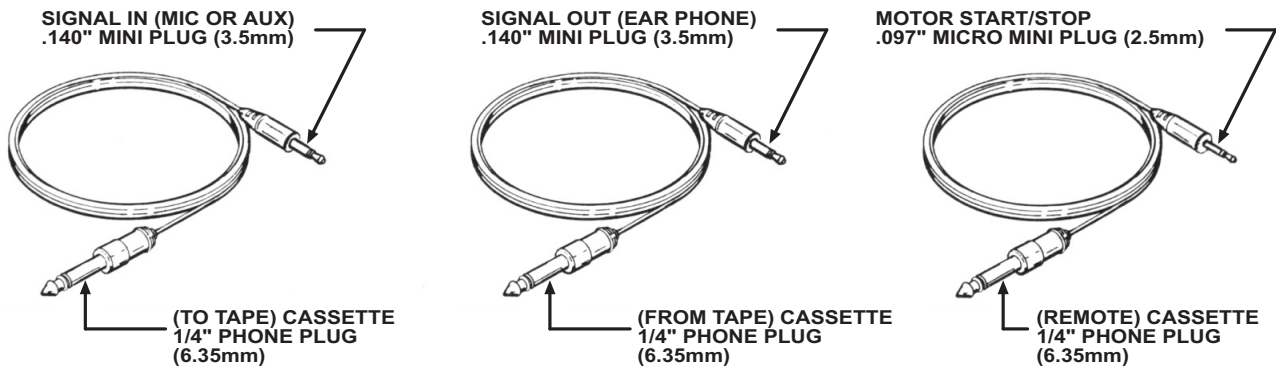

Connect the Memorymoog TO TAPE output to the MIC level input of the recorder. (Use only one channel of a stereo recorder.) Connect the Memorymoog FROM TAPE input to the EARPHONE (or line level) output of the recorder and, where applicable, connect the Memorymoog REMOTE jack to the REMOTE or START/STOP input of the recorder. If your recorder is not so equipped, start/ stop must be done manually.

If you don't have a small cassette tape recorder with automatic level control, there is a leader signal at the front of the cassette save function which you can use to set the level of your recorder. It should be set at around  $\pm 3$  on the VU meter to ensure sufficient level.

To save programs onto tape, hit PREFIX C, press 1, press ENTER. This starts the cassette save operation, which takes about 30 seconds. When saving to tape, your instrument is inoperative. When it's complete, the Alphanumeric Display will read "SAVED."

To verify that saving took place correctly, rewind the tape and press PREFIX C, hit 3, hit ENTER, and start the tape. When the tape has been completed, the Alphanumeric Display will read "VERIFIED" if the tape has been made properly. It will read "ERROR" if there's a problem. If the playback volume is too low, the Display will read "VOL LOW."

To load programs from a cassette tape, press PREFIX C, hit 2, hit ENTER. When the tape has been completed, the Alphanumeric Display will read "LOADED" if there wasn't any problem. It will read "VOL LOW" if the playback volume is too low, and it will read "ERROR" if there's some other problem. Generally speaking, you should always verify a tape before you try to load it.

## INTERFACING THE MEMORYMOOG TO A MONOPHONIC SYNTH

It's possible to control an external monophonic synthesizer using the INTERFACE jacks (14.0) provided on the Memorymoog's back panel.

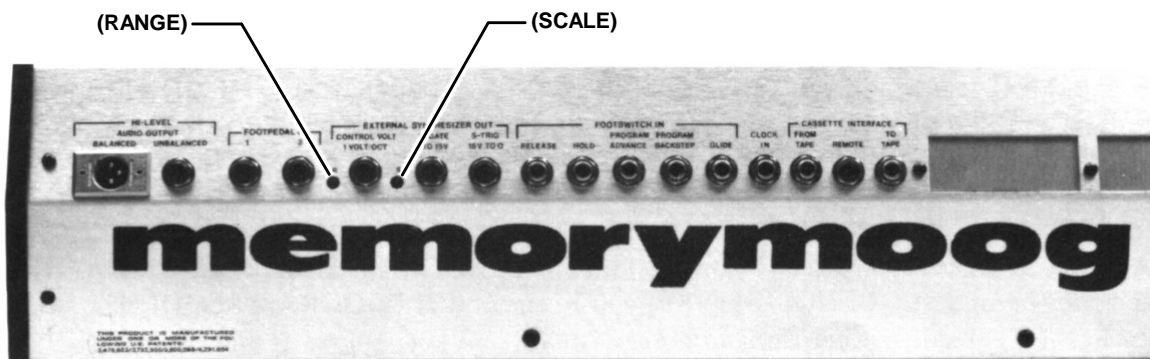

BACK PANEL

The CONTROL VOLT 1 VOLT/OCT jack is used to supply control voltage out from the Memorymoog to the external synthesizer. The other two jacks – V-GATE 0 TO 15V and S-TRIG 15V TO 0 – are used to supply either voltage or switch triggers from the Memorymoog to the external synthesizer, depending on which type of trigger signal it requires. Consult the owner's manual for the synthesizer you intend to interface to for details of the trigger signal required.

Once you've connected the necessary patch cords between instruments, it may be necessary to retune the Memorymoog output to the external synthesizer, especially if that synthesizer has a keyboard that ends in notes other than C. To do this, use the RANGE (R) and SCALE (S) trimpots on the back panel of the Memorymoog. The RANGE control lets you tune the Memorymoog output  $\pm$  an octave. Hit the lowest C on the Memorymoog, and tune it to the lowest C on the instrument you're interfacing to. The SCALE trimpot is used to tune the outer range of the Memorymoog output to the outer range of the instrument you're interfaced with. Hit the highest note on the Memorymoog and adjust the SCALE trimmer until it's in tune with the external synth. You may have to go back and forth between the RANGE and SCALE controls a bit before the instruments are exactly in tune with each other.

The KB OUT switch (1.5) on the front panel is used to disconnect the external synthesizer from the Memorymoog without unplugging all the patch cords. Its function is programmable.

## THE KEYBOARD

The keyboard is the source of control voltages that are applied to the oscillators, telling them what pitches to produce. The lower the note you play, the lower the corresponding voltage the keyboard will put out. It functions in two basic modes: POLYPHONIC and MONOPHONIC.

In its four POLYPHONIC MODES you can play up to six notes simultaneously. The keyboard puts out a separate control voltage for each voice card. There are four different ways that the computer assigns voices to the notes you play when you're in a POLYPHONIC mode. The effects of the different keyboard modes will not be apparent unless glide and/or long release times are turned on. To hear the various keyboard modes, use a fairly straight preset, a brassy one or something similar. Turn the GLIDE (1.6) on and set it at 5 or more. To set the mode of the keyboard, hit the KB MODE switch (1.7). The Alphanumeric Display (3.2) will then show "POLYPHONIC 1, 2, 3, or 4" depending on the keyboard mode programmed. Hit 1 on the Numeric Keyboard (3.3) followed by ENTER. This puts you in KEYBOARD MODE 1, which is called CYCLIC indicating that the voices will jump around to new notes every time one is played. Hitting a widely spread chord on the keyboard more than once, letting the glide finish its cycle, will let you hear that no matter how many times you strike the chord, each voice has glide on it.

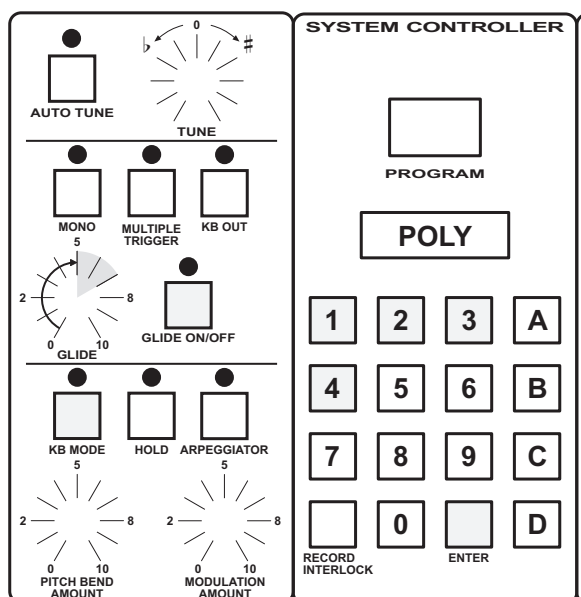

## POLYPHONIC KEYBOARD MODES

HIT KB MODE  
HIT 1  
HIT ENTER = KB MODE # 1

HIT KB MODE  
HIT 2  
HIT ENTER = KB MODE # 2

HIT KB MODE  
HIT 3  
HIT ENTER = KB MODE # 3

HIT KB MODE  
HIT 4  
HIT ENTER = KB MODE # 4

Next, hit KB MODE, hit 2, hit ENTER. That will put the keyboard in POLYPHONIC MODE 2, CYCLIC WITH MEMORY. Now when you repeat the same chord over and over again, you should only hear glide the first time you strike the chord. The second and each consecutive time you strike that chord, the computer memory remembers that the voices have been assigned to the various pitches you are playing. It won't reassign them until you hit a new note or set of notes.

Hit KB MODE, hit 3, hit ENTER. This gets you to KEYBOARD MODE 3, RESET TO VOICE A. Every time you let up on all the notes on the keyboard, the next note you hit will be assigned to VOICE A. Playing a single line will produce a sound similar to playing the same line on a monophonic synthesizer.

Hit KB MODE, hit 4, hit ENTER to hear KEYBOARD MODE 4, RESET TO VOICE A WITH MEMORY. The effect is just like that of CYCLIC WITH MEMORY in that when you strike the chord repeatedly, you only hear glide the first time you hit the chord. From then on the instrument remembers that the voices have been assigned specific notes and it won't reassign them until you strike new notes. This mode differs from CYCLIC WITH MEMORY in that the first note played after no notes have been held down is assigned to VOICE A.

In MONOPHONIC MODE, the keyboard will only let you play one note at a time. There are three different MONOPHONIC PRIORITY modes that determine what note sounds should you play more than one note at a time when in MONO MODE. To get to the MONOPHONIC KEYBOARD MODES, turn the MONO switch (1.3) on. Then hit the KB MODE switch (1.7), and press either 1, 2, or 3, followed by ENTER. KEYBOARD MODE 1 is last note priority – the last note played will sound over all others no matter how many notes you hold down. KEYBOARD MODE 2 is low-note priority – the lowest note played gets priority. KEYBOARD MODE 3 is high-note priority – the highest note will sound if more than one note is played. All three modes have interesting uses, especially when used in conjunction with the SINGLE/MULTIPLE TRIGGER switch (1.4) and/or when the Memorymoog is interfaced with a monophonic synthesizer.

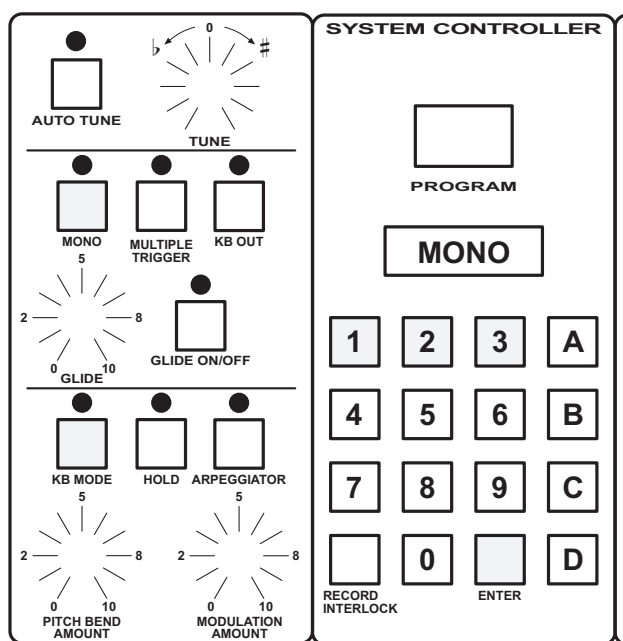

## MONOPHONIC KEYBOARD MODES

HIT KB MODE  
HIT 1  
HIT ENTER = KB MODE # 1

HIT KB MODE  
HIT 2  
HIT ENTER = KB MODE # 2

HIT KB MODE  
HIT 3  
HIT ENTER = KB MODE # 3

## **CHANGING THE NUMBER OF VOICES THE KEYBOARD CONTROLS IN MONO MODE**

When you put the keyboard into its MONOPHONIC MODE by pressing the MONO switch (1.3), the keyboard will play only one note at a time. It will control from 1 to 18 oscillators, depending on how many voice cards are being controlled. You can program the number of voice cards controlled by turning the MONO switch (1.3) on, hitting the KB MODE switch (1.7), pressing ENTER, and then hitting a number from 1 to 6 on the Numeric Keyboard (3.3), and pressing ENTER again. If you hit a 1, you will control three oscillators as a Minimoog does. If you want to hear the sound of only one oscillator, turn the volume controls in the MIXER (7.0) of two of the oscillators to 0. The more oscillators you control, the thicker and fatter the sound will be. Controlling all 18 oscillators in unison creates a very massive sound.

### **SINGLE/MULTIPLE TRIGGER**

When the SINGLE/MULTIPLE TRIGGER switch (1.4) is off, the keyboard waits until all keys are released before a new key depression will put out a new trigger signal, which is used to start the CONTOUR GENERATORS (8.5 and 9.0). This state is called SINGLE TRIGGERING, and it's useful for playing legato passages in MONO MODE.

You can emphasize phrases in SINGLE TRIGGER MODE by deliberately attacking only the first note in a phrase, playing the rest of it with a legato touch. This produces only one trigger for the entire phrase, emphasizing the first note, letting the others be played with what remains of the single CONTOUR. If you've never played a single-trigger monophonic synthesizer before, it may take some practice to get used to the technique. With this patch try playing a familiar run or scale, producing new triggers only at the first note. Do it slowly to begin with and increase the speed as you start to master the technique. Also, try the different KEYBOARD MODES while you practice and notice the differences in priority between high-note, low-note, and last-note modes.

### **SINGLE/MULTIPLE TRIGGER**

With the SINGLE/MULTIPLE TRIGGER switch (1.4) on, the keyboard will put out a new trigger for every note played, regardless of whether or not any other note is still being held down. You'll notice that if you try to play legato, the keyboard will still put out new triggers, foiling your every attempt to avoid them. MULTIPLE TRIGGERING is great for playing those pyrotechnic runs where you want every note to stand out. It covers up for any note you hit sloppily, whereas with SINGLE TRIGGERING, you have to be sure to hit every note distinctly in order for it to be articulated clearly.

## THE HOLD FUNCTION

The HOLD switch (1.8) is used for building chords that you can subsequently control in parallel motion from the keyboard. Play a chord. Continue holding it while you press the HOLD button. Let up on the chord and then play a single note. You should hear the chord and be able to transpose it up and down by playing the keyboard. If you want to build chords that are too wide to simultaneously play while pressing the HOLD switch, push the HOLD switch, continue holding it and play the chord you want, one note at a time. When the HOLD switch is released, the chord pattern is stored. Since the HOLD function is *not* programmable, you can switch to other programs while retaining the "held" chord.

## THE ARPEGGIATOR

Turning the ARPEGGIATOR switch (1.9) on puts the keyboard immediately into a MONOPHONIC ARPEGGIATION MODE. However, if the instrument is in MONOPHONIC MODE already, no arpeggiation will occur. You'll hear the highest, lowest, or last note you've hit retrigger depending on the MONO KEYBOARD MODE you're in. The rate of the arpeggiation is set by the LFO RATE knob (5.0).

When you first turn on the arpeggiator, the Alphanumeric Display will read "MODE (1-9)" (the arpeggiator modes are listed below). To change the ARPEGGIATION MODES, hit the desired MODE NUMBER followed by ENTER immediately after you turn on the ARPEGGIATOR.

### ARPEGGIATION MODES

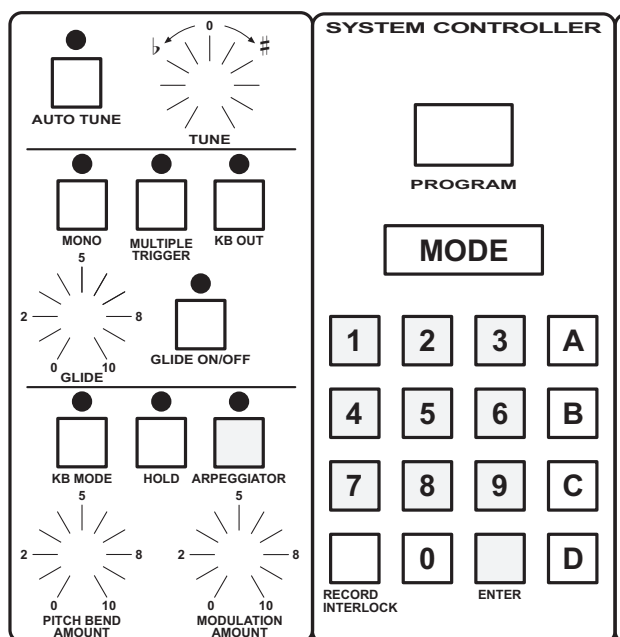

#### TURN ARPEGGIATOR ON



- HIT 1  
HIT ENTER = MODE 1, UP
- HIT 2  
HIT ENTER = MODE 2, DOWN
- HIT 3  
HIT ENTER = MODE 3, UP-DOWN
- HIT 4  
HIT ENTER = MODE 4, UP (LATCHED)
- HIT 5  
HIT ENTER = MODE 5, DOWN (LATCHED)
- HIT 6  
HIT ENTER = MODE 6, UP-DOWN (LATCHED)
- HIT 7  
HIT ENTER = MODE 7, AUTO TRIGGER (ALL VOICES TRIGGERED SIMULTANEOUSLY)
- HIT 8  
HIT ENTER = MODE 8, FIRST TO LAST
- HIT 9  
HIT ENTER = MODE 9, FIRST TO LAST (LATCHED)

## THE OSCILLATORS

The 18 voltage-controlled oscillators of the Memorymoog produce the pitches you hear when you play the keyboard. The control voltage output from the keyboard determines the oscillators' pitch. Pitch is supplied by an oscillator when its waveform, a periodic fluctuation of voltage, is translated by a speaker cone into a fluctuation of air, which we perceive as pitch. There are a number of things which can alter the speed or frequency of the oscillators: incoming control voltages supplied by the keyboard, the FREQUENCY controls on the oscillators themselves (6.5 and 6.6), voltage from the two PROGRAMMABLE FOOTPEDALS (4.0), the PITCH BEND WHEEL (2.2), the LFO (5.0), the filter's CONTOUR GENERATOR (8.5), and the output of OSCILLATOR 3 when it's used as a modulation source in the VOICE MODULATION section (5.4).

As we explained in the introduction, each voice card holds three oscillators. There are six voice cards for a total of 18 oscillators. Each of the oscillator panel controls for OSCILLATORS 1, 2, and 3 actually governs six oscillators. To avoid confusion when we refer to OSCILLATOR 1, OSCILLATOR 2, and OSCILLATOR 3, we'll mean the set of six oscillators governed by each of those groups of controls.

## WAVESHAPE

Each oscillator generates three waveshapes: pulse , sawtooth , and triangle . Each waveshape is a representation of fluctuations of voltage. These fluctuations produce different sets of harmonics, thereby creating a different timbre of tone color. If you want to listen to how they differ, set up this patch (start by pressing C, 9, ENTER on the NUMERIC KEYBOARD [3.3] to get a live panel):

**TO HEAR THE DIFFERENT WAVESHAPES . . .**

**HOLD DOWN A NOTE IN THE CENTER OF THE KEYBOARD. TURN ON EACH WAVESHAPESWITCH INDIVIDUALLY AND LISTEN TO THE EFFECT IT HAS ON THE TONE COLOR. TURN THE PULSE WIDTH CONTROL WHEN YOU GET TO THE PULSE WAVE AND NOTICE HOW CHANGING THE WIDTH OF THE PULSE WAVE AFFECTS ITS TONE.**